



# OIL RECOVERY CENTRIFUGE (Automatic)



Oilmax

## Recover Oil From Chips & Components



- No manual interference
- Complete Oil Recovery
- Improved Product Finish
- Reduced Oil Consumption
- Save Over 5000 Ltrs Oil Per Month
- Substantial Savings On Cost of Oil
- Reduced Pollution & Environmental Impact

Use your *Oil maximum*

## Recover Oil, Save On Oil Cost



### Industries

- Gear Manufacturing
- Fastener Manufacturing
- Spring Manufacturing
- Auto Component Manufacturing
- Brass Component Manufacturing

[Presentation](#)



### Applications

[Gear Hobbing](#)



[Broaching](#)

[Multi Spindle Machine](#)



[Traub Machine](#)

[Deep Hole / Gun Drilling](#)



### Cost Saved

Customer	Period	Oil Recovered (L)	Savings (Rs.)
Tata Motors, Jamshedpur	33 Months	1,50,268	1.65 CR
Ramkrishna Forging, Jamshedpur	50 Months	1,89,430	2.08 CR
Turbo Gear, Pune	41 Months	1,94,580	2.14 CR
Kirloskar Pneumatic, Pune	37 Months	80,674	1.46 CR
<b>Grand Total</b>		<b>6,17,705</b>	<b>7.39 CR</b>



[Sample ROI](#)



One Time Installation, Lifelong Savings

# Working Principle

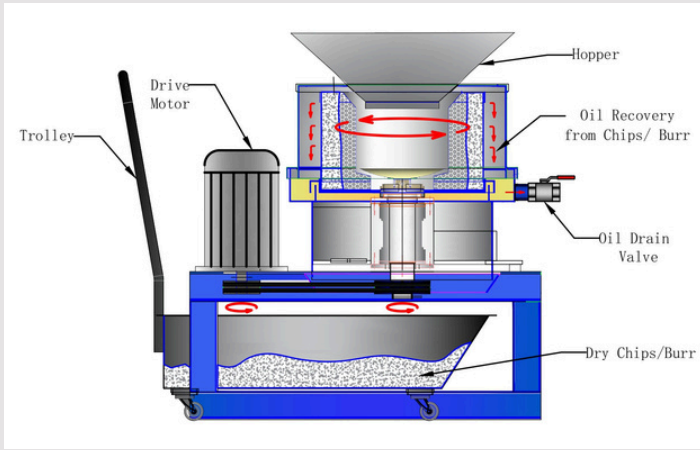

Oil Recovery Centrifuge works on principle of centrifugal separation. Rotor bowl made of perforated steel screen is driven by motor. Chips / Parts from which oil is to be recovered are loaded in the rotor bowl. Centrifugal force created in the rotor separates oil from surface of Chips / Parts.

Collected oil is drained out by opening valve provided at the bottom of unit. Chips automatically gets collected in trolley at the bottom of machine after each cycle.

## Installations



## Specifications

Model	ORC 40 AD	ORC 75 AD
Rotor Volume (Ltr.)	40	75
Processing Capacity (Kg/hr.)	100 to 120	150 to 180
Motor Power (HP)	2	3
Dimensions (Inches)	39" x 33" x 43"	48" x 37" x 48"
Weight (Kg)	260	300

## Customers



**Oilmax Systems Pvt. Ltd.**

38/2/12, Narhe-Pune 411041 (India), Tel : [+91 7776078885](tel:+917776078885), [+919881895950](tel:+919881895950)

Email: [mail@oilmax.co.in](mailto:mail@oilmax.co.in) Web: [www.centrifugaloilcleaner.com](http://www.centrifugaloilcleaner.com)

