



CENTRIFUGAL OIL CLEANER

Oilmax

For Diesel Engines



Reduce Engine operating & Maintenance expenses

- ◆ No Replacement Element
- ◆ No Recurring Cost
- ◆ Increased Engine Life
- ◆ Improved Engine Operation
- ◆ Extended Oil Change Period
- ◆ Finest filtration below 1µ
- ◆ Substantial savings on operating & Maintenance expenses



Use Oilmax
Save Environment

One Time fitment, Lifelong Savings

Schematic Diagram - Full Flow Filter & Centrifugal Oil Cleaner

Full flow filter carries entire oil flowing to various engine components, hence it has coarse filter element of 30 to 50 µ (to meet the flow requirement of engine components.) It removes large particles, however fine particles remain in the oil. Centrifugal oil cleaner is installed in bypass line. It is a multipass cleaning system, it processes small quantity of oil continuously & removes all the Particles present in the lube oil down to 1µ, thereby achieving very high level of oil cleanliness.

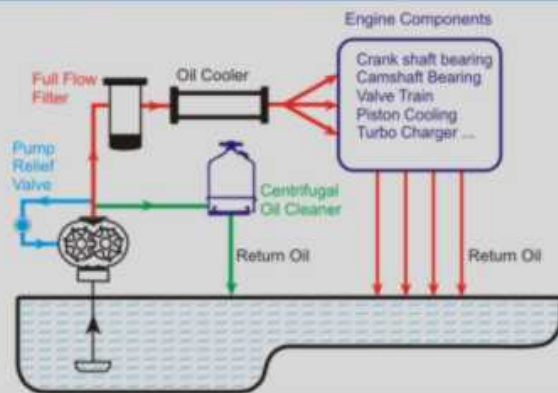

Expenses Saved Is Profit Earned



With Oilmax Centrifugal Oil Cleaner substantial savings can be achieved on three major engine operating expenses i.e. cost of Lube oil, Filters and Engine overhauling.

Save with Oilmax

Bypass Filter	Save 100%
Full Flow Filter	Save 50 to 100%
Engine Oil	Save 50 to 100%
Overhauling	Save 50 to 100%

Standalone System

Oilmax Centrifugal oil Cleaner is also available as Complete Standalone system, including Motor, Gear pump, Pressure gauge, Electrical switch gear etc., it is useful for cleaning onboard oils like Gear oil, Transmission oil, Hydraulic Oil, Fuel Oil, Stuffing Box Oil etc. It can also be used for cleaning engine lube oil of low rpm engines (with pressure upto 3 bar). The unit is mounted on wheels and can be easily moved.



Applications

- ◆ Auxiliary Engines
- ◆ Main Propulsion Engines
- ◆ On Boards Cranes
- ◆ RTG Cranes
- ◆ Reach Stackers
- ◆ Stuffing Box Oil
- ◆ Gear Box Oil
- ◆ Hydraulic Oil

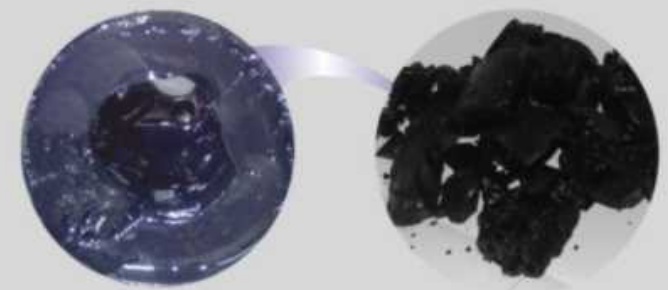

Dirt Removed From Engine Oil

Working Principle

Centrifugal oil cleaner operates on reaction turbine principle. Oil enters centrifuge under pressure and flows into rotor thru hollow rotor shaft. The oil pressure and flow is converted in rotational energy as oil escapes through the rotor jets, producing speed upto 8000 rpm. The resultant centrifugal force removes dirt from the engine oil, depositing it on the inner wall of rotor in a dense cake form. Clean oil drains back to the engine oil by gravity.

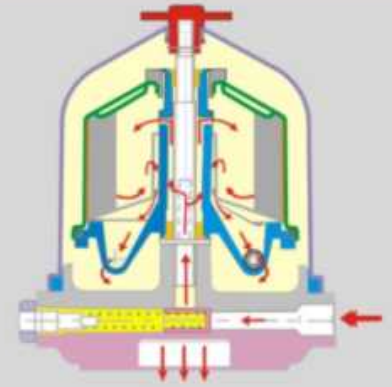

Why Centrifugal Oil Cleaner

Centrifugal Oil Cleaner removes very fine dirt from lube oil below 1µ. Present engine filtration system can not remove such fine particles. With clean lube oil, Engine wear & tear is Substantially reduced, particularly of the tight clearance components like Piston Rings and Liners, Camshafts & Bearings, Turbo Charger, Gear Train etc. Effective removal of Carbon soot prevents Ring sticking and Clogging of oil passages, improving engine performance.

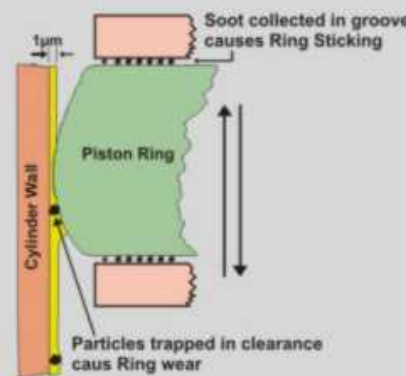

Fine particles in the range of 1-5µ get trapped into the dynamic clearance causing the maximum wear & tear. Centrifugal oil cleaner removes these fine particles enabling extension of Engine life

Installations



Selection Chart - Engine Mounted Centrifuge

Centrifuge Model	SCC 020	SCC 025	SCC 030	SCC 050	SCC 060	SCC 100	SCC 200	SCC 400	SCC 600
Nominal Flow Rate	200 LPH	250 LPH	300 LPH	500 LPH	600 LPH	700 LPH	1200 LPH	3000 LPH	4000 LPH
Dirt Holding Capacity	200 cc	250 cc	300 cc	500 cc	600 cc	1000 cc	2000 cc	4000 cc	6000 cc
Engine Oil Sump	20 Ltrs.	30 Ltrs.	50 Ltrs.	60 Ltrs.	80 Ltrs.	120 Ltrs.	700 Ltrs.	1500 Ltrs.	3000 Ltrs.

Selection Chart - Standalone System

Oil Cleaning System Model	Centrifuge Model	Nominal Flow Rate	Dirt Holding Capacity	Dimension (W x D x H) Inch
OCS 500	SCC 075	500 LPH	500 cc	22 x 12 x 33
OCS 750	SCC 100	750 LPH	1000 cc	22 x 12 x 35
OCS 1500	SCC 200	1500 LPH	2000 cc	24 x 13 x 39
OCS 4000	SCC 600	4000 LPH	6000 cc	30 x 16 x 44



Oilmax Systems Pvt. Ltd.

37/2, Ashvinayak Ind. Estate, Narhe, PUNE - 411 041 (INDIA)
Tel. +91 20-25431052, 25467041, Web: www.oilmaxsystems.com
E-mail : marketing@oilmax.co.in / export@oilmax.co.in

